

AUDIOVOX[®]
ELECTRONICS CORP.

DS7 / DS85 / D102 DOCKING STATION

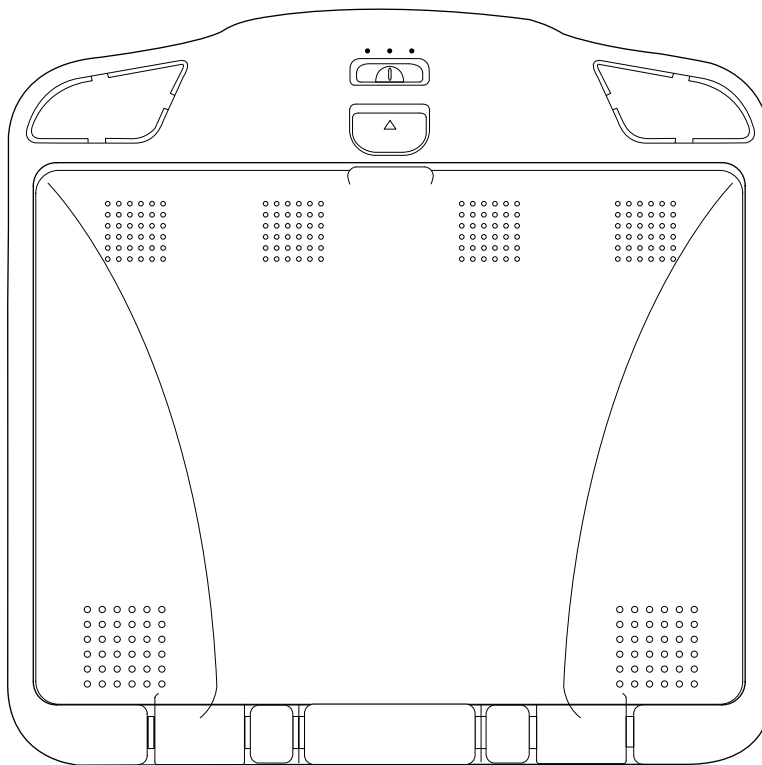

Installation Guide

Important Notice

An LCD panel and/or video monitor may be installed in a motor vehicle and visible to the driver if the LCD panel or video monitor is used for vehicle information, system control, rear or side observation or navigation. If the LCD panel or video monitor is used for television reception, video or DVD play, the LCD panel or video monitor must be installed so that these features will only function when the vehicle is in "park" or when the vehicle's parking brake is applied.

An LCD panel or video monitor used for television reception, video or DVD play that operates when the vehicle is in gear or when the parking brake is not applied must be installed to the rear of the driver's seat where it will not be visible, directly or indirectly, to the operator of the motor vehicle.

MATERIALS INCLUDED IN THIS PACKAGE:

- 1) Over Head Docking Station – (1 pc)
DS7 (P/N 136-3952) / DS85 (P/N 136-3953) / DS102 (P/N 136-3954) - (1pc)
- 2) Lamp Harness (P/N 112B3110) – (1 pc)
- 3) 2 Pin Power Wire Harness with choke (P/ N 112B3143) – (1 pc)
- 4) Hardware Package
Screws (#4) – (8 pcs)
Self Drilling Screws (#8) – (4 pcs)
Screws (M5) – (4 pcs)
Nut (M5) – (4 pcs)
Washer – (4 pcs)
- 5) Trim Ring (DS102=P/N 102-4110) (DS85=P/N 102-4124) (DS7=P/N 102-4125) – (1 pc)
- 6) Mounting Bracket (DS7 & DS85 P/N 108-3856) (DS102 P/N 108-3865) – (1 pc)

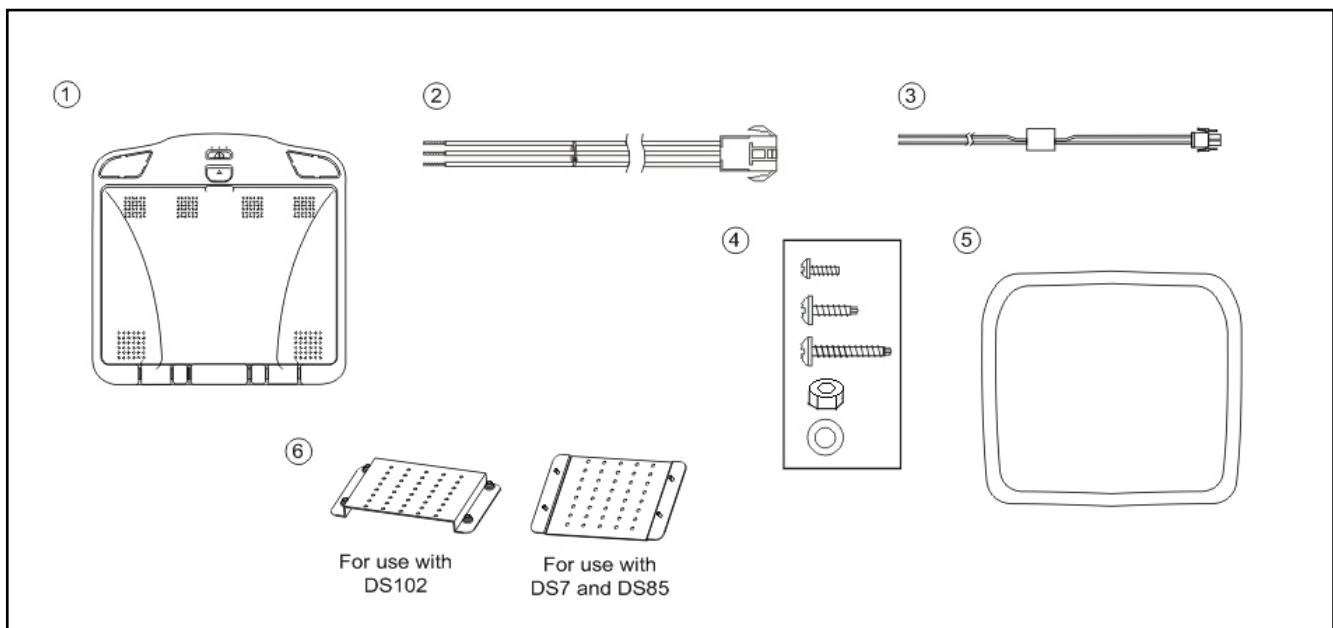

TOOLS REQUIRED:

- Nut Driver / Socket Wrench
- #2 Phillips Screwdriver
- #1 Phillips Screwdriver
- Utility or Razor Knife or Shears
- Wire Strippers
- Upholstery hook tool (for removal of panels as necessary)
- Electrical Tape
- Masking Tape
- Multimeter (to verify 12 volt DC and continuity: Do not use a test light or logic probe)
- Marker pen – to mark headliner
- Scribe (to mark trim ring if used)
- Misc. electrical connectors (to connect to vehicle power source). Requirements will vary from vehicle to vehicle)

DS7 / DS85 / DS102

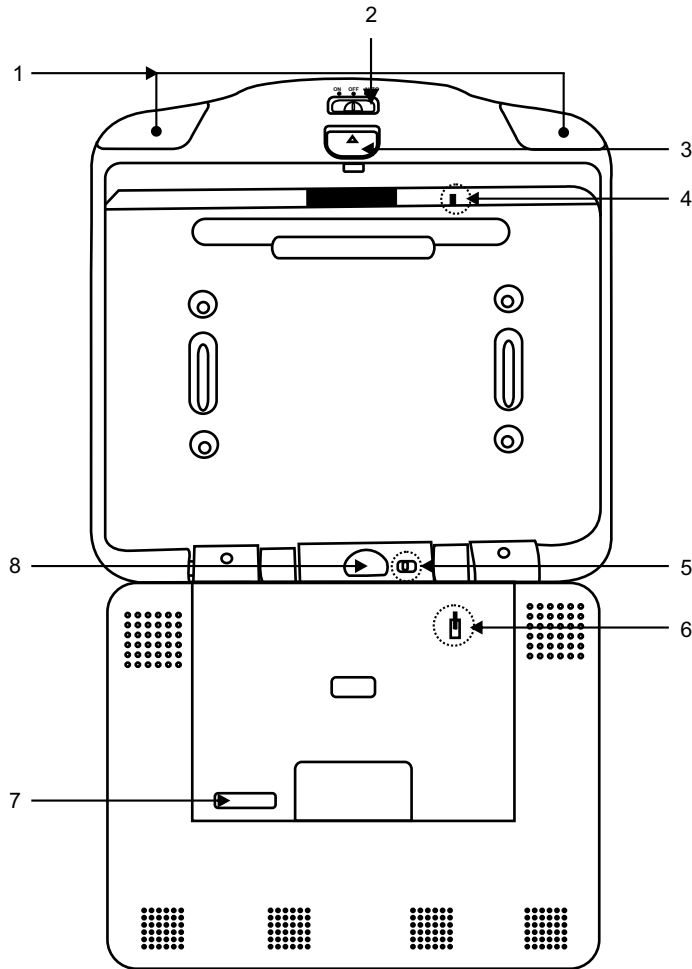

- 1) Dome Lights – Provide additional interior illumination.
- 2) Three position Dome light switch
 - Auto – Automatically switches on the dome light in conjunction with the vehicle's interior illumination.
 - OFF – The dome Lights will not turn on in this position.
 - On – Turns on the dome lights.
- 3) Screen Release – Moves in direction of the arrow to release the drop down screen.
- 4) Shuttle Shut-off switch.
- 5) Security Lock Knob
- 6) Shuttle Power Switch Connector.
- 7) Tablet connector 12 pin.
- 8) Shuttle Release – Moves in direction of the arrow to release the shuttle unit.

GENERAL INSTALLATION APPROACH:

- 1) Decide upon system configuration and options that will be installed.
- 2) Review all manuals to become familiar with electrical requirements and hook ups.
- 3) Decide upon mounting locations of all components and method of mounting.
- 4) Prep the vehicle by removing any interior trim necessary to gain access to vehicle's wiring as well as all areas where interconnecting wire harnesses will need to be located. If any access holes need to be cut into the vehicle (headliner, other trim components etc.), this should be done now as well. (Refer to Page 3).
- 5) Route the wiring harnesses throughout the vehicle as necessary. (Refer to the Wiring Diagrams on pages 6 of this manual as well as the wiring instructions for the individual components and accessory options being installed). Be sure that all wiring is protected from sharp edges and is routed in such a manner that it will not be pinched when all components and interior trim are fully installed. Be sure to leave enough slack in the wiring at each component to allow working room.
- 6) Remove all A/V system components from their packaging and place them loosely in the vehicle at their respective locations.
- 7) Connect all components together (electrically) and verify proper operation of all system functions.
Note: This is best done BEFORE, components have been permanently mounted.
- 8) After verifying proper operation of the system, proceed to mount of each component.
- 9) When all components are mounted, recheck function of entire system again to ensure that no wiring was pinched or connected improperly during final installation.

SYSTEM OPTIONS:

There are a few audio output options that can be added as follows:

- a) Wireless Headphones (P/N MVIRHS).

The DS7/DS85/DS102 video system is only intended for an overhead, drop down installation. It is not intended for Seatback or any other type of mounting. The hinging mechanism is designed for horizontal, drop down use only.

VEHICLE PREPARATION:

- 1) Locate an accessory power source (+12v when key is in the ACC. and run positions, and 0v when key is off), and also a good ground generally, these wires can be found at the ignition switch or fuse-box.
- 2) The mounting method and location will vary from vehicle to vehicle, so this manual will only focus on the installation of the video monitor and related console accessories.
- 3) Generally, the best location for the video monitor is where the vehicle's factory dome light is installed. The monitor should be located in such a manner that it can be comfortably viewed by rear seat passengers. **NEVER INSTALL THE MONITOR IN A PLACE WITHIN THE DRIVER'S VIEW. THIS IS NOT ONLY DANGEROUS, BUT IT IS ALSO ILLEGAL IN MANY STATES.**
- 4) Once the mounting location of the monitor has been determined, there may be additional preparation work necessary, depending on the vehicle structure and installation method. Some of the steps that may be required are:
 - A) Removal of the vehicle's dome light
 - B) The headliner may.
 - C) If the trim ring will be used, it will have to be trimmed to fit the contour of the vehicle's headliner. Refer to the "Trim Ring installation" section in this manual.

TRIM RING INSTALLATION:

This page only covers special installation considerations for the trim ring installation. If the docking station is to be installed in a vehicle with the trim ring, it may need to be trimmed to fit the contour of the vehicle headliner.

- 1) In this installation, the docking station is mounted directly to the overhead cross-member in the roof using the mounting screw bosses. These screw bosses should contact the cross-member directly (i.e.: no gap between the screw boss and the roof structure). Also, be sure that the screws do not pierce the outer roof skin when fully fastened to the cross-member. The trim ring is attached to the docking station using the perimeter screw bosses. It is important that the screws used in this installation are not over tightened, and that the docking station and trim ring are mounted in such a way that the assembly does not distort (or bend) when the mounting screws are tightened. An alternate method is to use the supplied mounting bracket. See the drawing on pages 6 and 7.
- 2) It is best to mount the docking station to the roof structure without the trim ring first. There should be a gap between the headliner and the outer flange of the docking station. The trim ring should be cut to full this gap. Apply masking tape to the outer surface of the trim ring in the areas where the cut will be made.
- 3) Mark the cut to follow the necessary contour of the roof. The suggested method of marking is as follows:
 - A) First mark the narrowest point of the trim ring on the masking tape. Be careful to consider not only vertical location, but fore-aft location.
 - B) Using the handle of a screwdriver, make a "transfer marking tool". See diagram below. Place the tool against the roof and the marker against the masking tape on the trim ring. Trace the cut to be made around the entire perimeter of the trim ring.
 - C) Cut the trim ring using a sharp utility knife or shears. Make the cut in several passes over the marked line, each time cutting a little deeper. It is not necessary to cut completely through the plastic, the cut only need be over 50% of the wall thickness of the plastic. By bending the cut back and forth several times, the plastic will break cleanly at the cut.
 - D) Check the fit of the trimmed console and make any minor adjustments necessary.
- 4) The finished trim ring should be attached to the docking station, then attach the assembly to the roof.

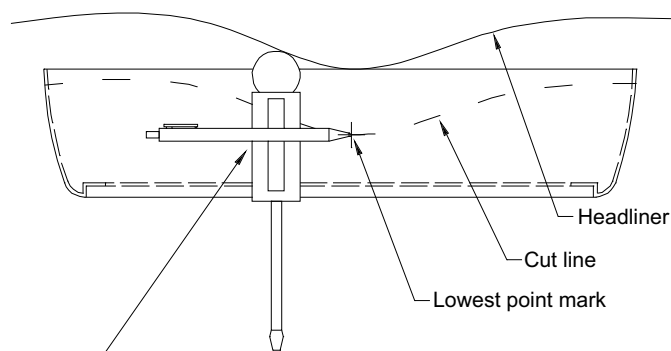

Tape marker to screwdriver.
Starting at your mark for the
lowest point, trace the contour of the roof

MOUNTING THE TRIM RING (DS7 and DS85)

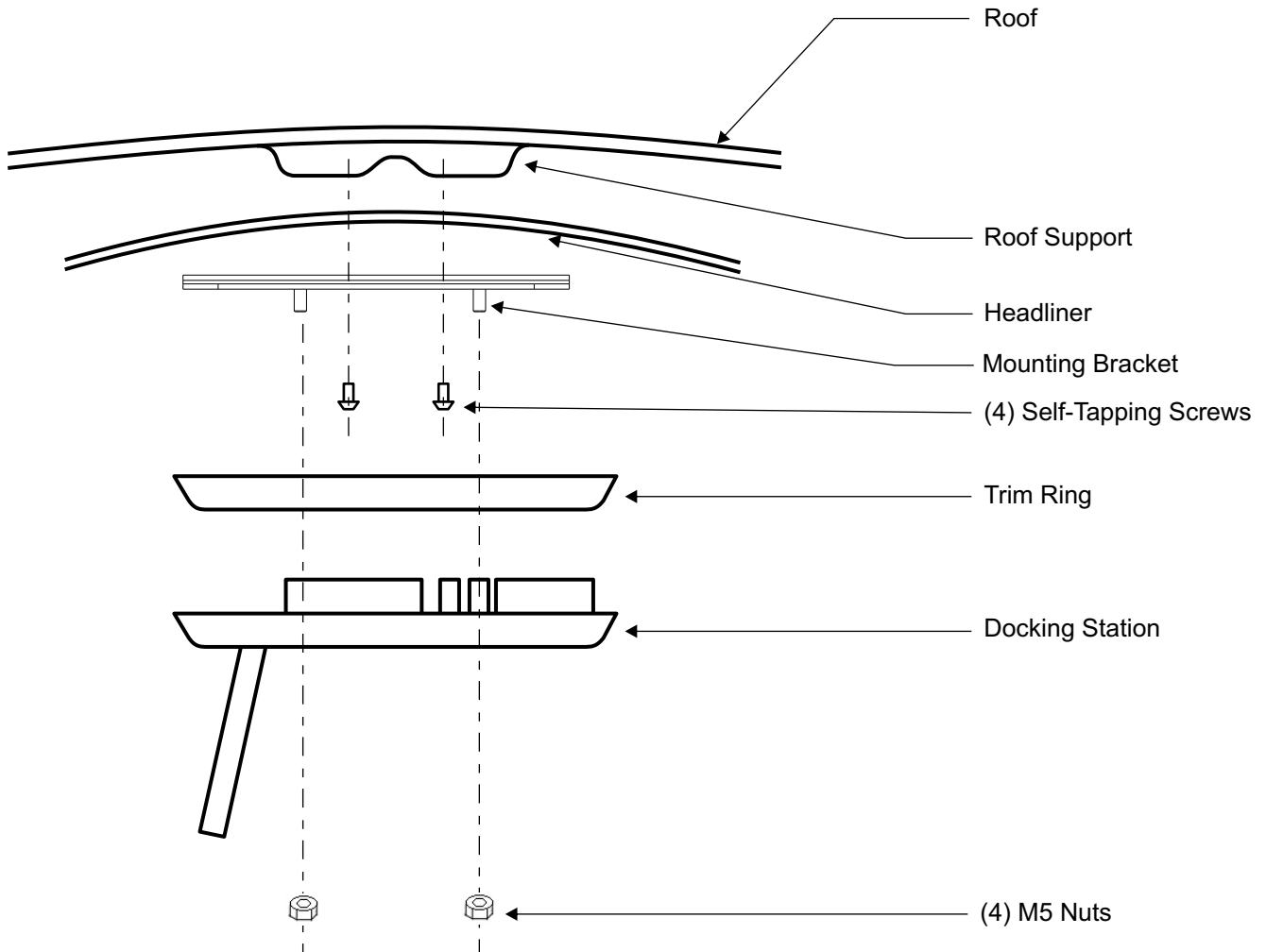

NOTE: Use care when screwing the bracket to the roof support, so to avoid damaging the roof of the vehicle

MOUNTING THE TRIM RING (DS102)

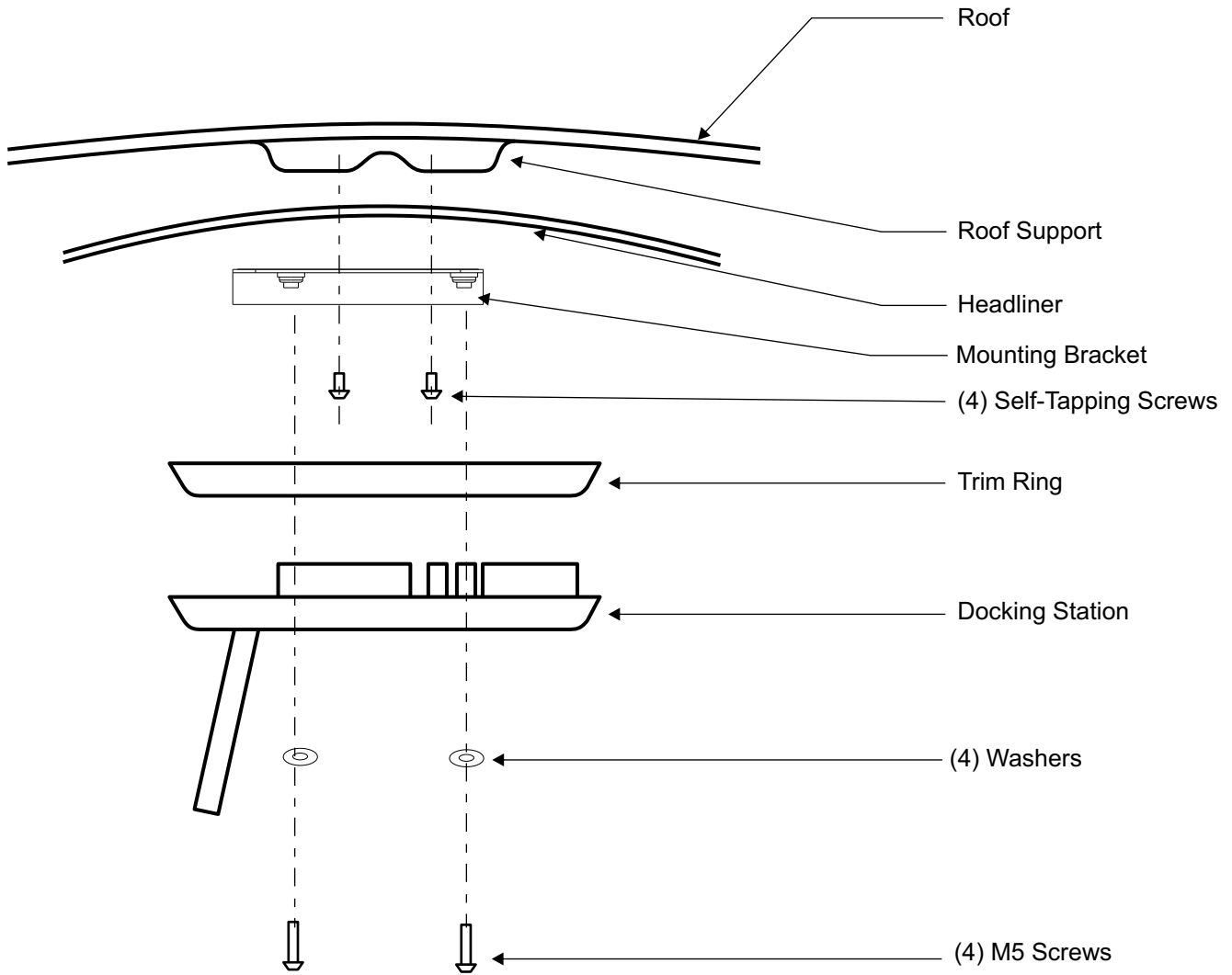

NOTE: Use care when screwing the bracket to the roof support, so to avoid damaging the roof of the vehicle

DS7 / DS85 / DS102

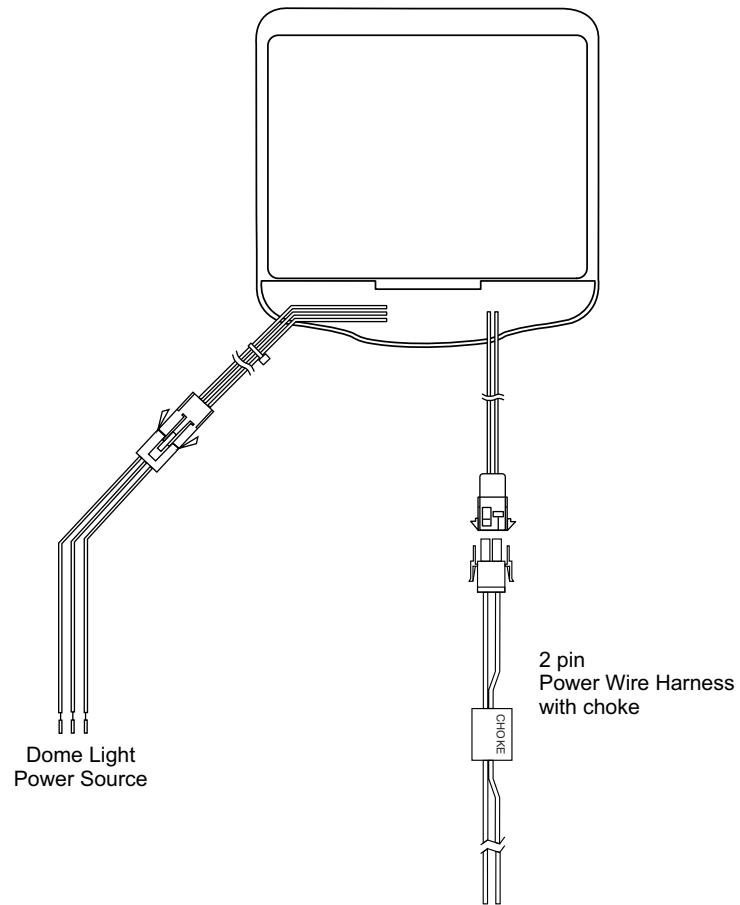

- 1) Make the connections to the vehicle for the 12 pin wiring harness.
- 2) Connect power harness to vehicle's electrical system by tapping into an accessory hot line and a good ground.
- 3) Verify all functions of the System before final mounting of the finished assembly.

CONNECTING THE DOME LIGHTS

The dome lights in the docking station require three connections to the vehicle's wiring. There are two common types of dome light circuits used, positive or negative switched. Positive systems supply voltage to the interior lights to turn them on, negative switched systems apply ground to illuminate the bulbs. To determine which system you have you must locate the wires at the dome light. On a positive switched system, with all the doors closed and the lights out, both wires at the dome light will rest at ground. When the light is activated, one of these wires will switch to +12 vdc. This is the vehicle's switching wire. On a negative switched system, with all the doors closed and the lights out, both wires at the dome light will rest at +12vdc. When the light is activated, one of these wires will switch to ground. This is the switching wire. For positive systems, connect the purple / brown (Lamp auto) wire to the vehicle's switched wire. Then connect the red / black (lamp on) wire to a fused constant 12 volt source and the black / red (lamp common) wire to a good ground. Positive systems are commonly found on Ford vehicles. For negative systems, connect the purple / brown (Lamp auto) wire to the vehicle's switched wire. Then connect the red / black (lamp on) wire to a good ground and the black / red (lamp common) wire to fused constant 12 volt source. Negative systems are commonly found on General Motors and import vehicles.

Note:

Some vehicles which incorporate transistorized control of the dome light circuit, such as the 1999 Dodge Caravan, may require that the purple / brown (Lamp auto) wire be connected to the door pin switch wire, as the additional current draw of the Monitor's lights may not be supported by the output of the vehicles body control computer.

Positive Switched Dome Lighting

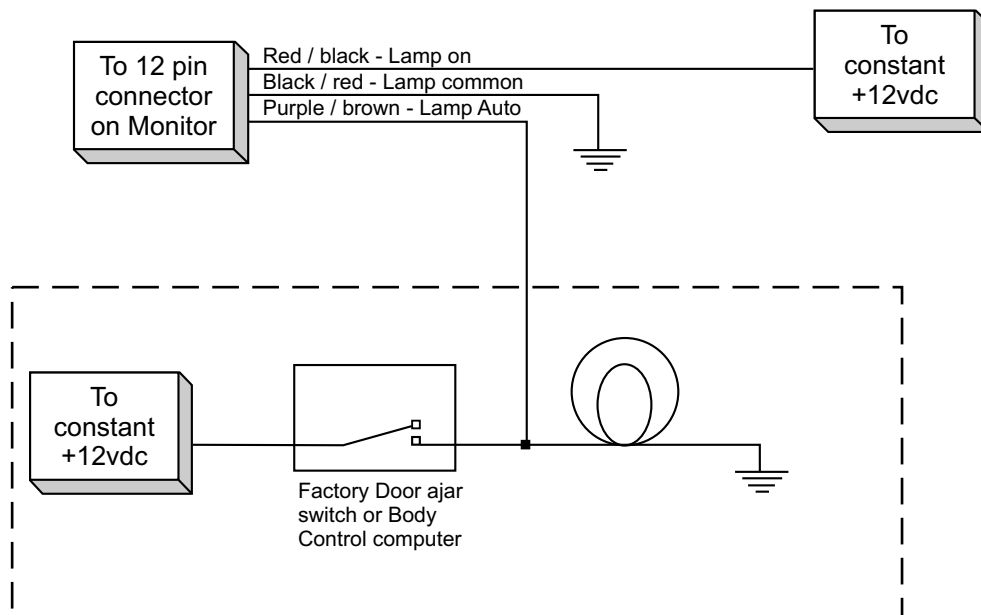

Negative Switched Dome Lighting

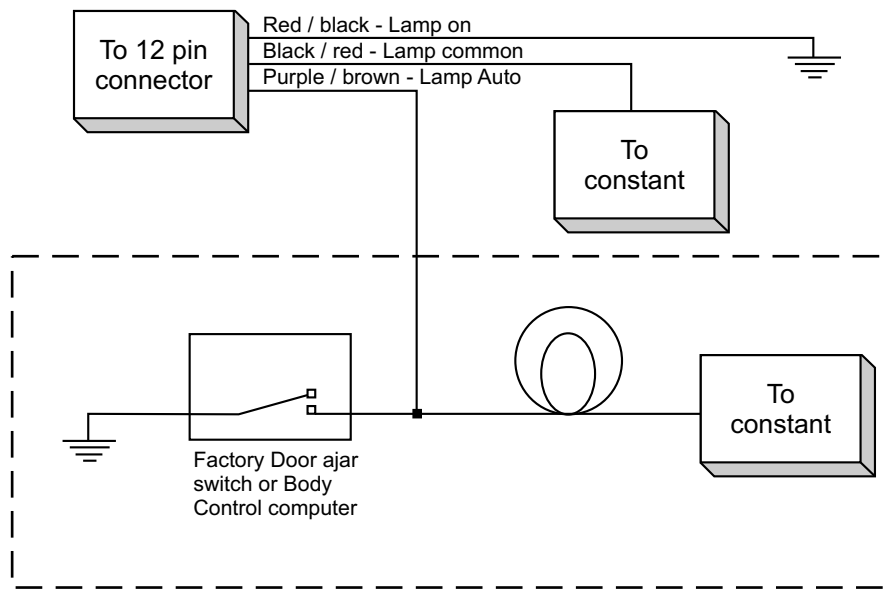

Troubleshooting:

SYMPTOM:

No power at Video Monitor

REMEDY:

Verify +12 VDC on Red wire at 2 pin Power Harness behind Docking Station. Verify ground connection with continuity test from known good ground to black wire at 2 pin Power Harness



For Customer Service
Visit Our Website At
www.audiovox.com
Product Information, Photos,
FAQ's Owner's Manuals

128-7345